

MAGNABEND CENTRELESS HINGE SE2 - ASSEMBLY

30 August 2019

PATENT NUMBERS: USA: 4,513,475, Australia: 560,457, EPO: 0092943. INVENTOR: G J FENTON

MOUNTING BLOCK.

Investment cast steel AISI 1045.
Mount to magnet body using
2 M8 x20 SHCS screws.

DOWEL PIN,
Dia 12 x 100

2 Holes for applying
#290 Loctite after
inserting dowel pin.

HINGE PLATE. Investment cast
Aluminium Bronze, alloy AB2.

Apply grease to all working
surfaces during assembly.

After bolting to the Magnet Body and
aligning, the hinge mounting blocks are
stabilised by welding along this edge.

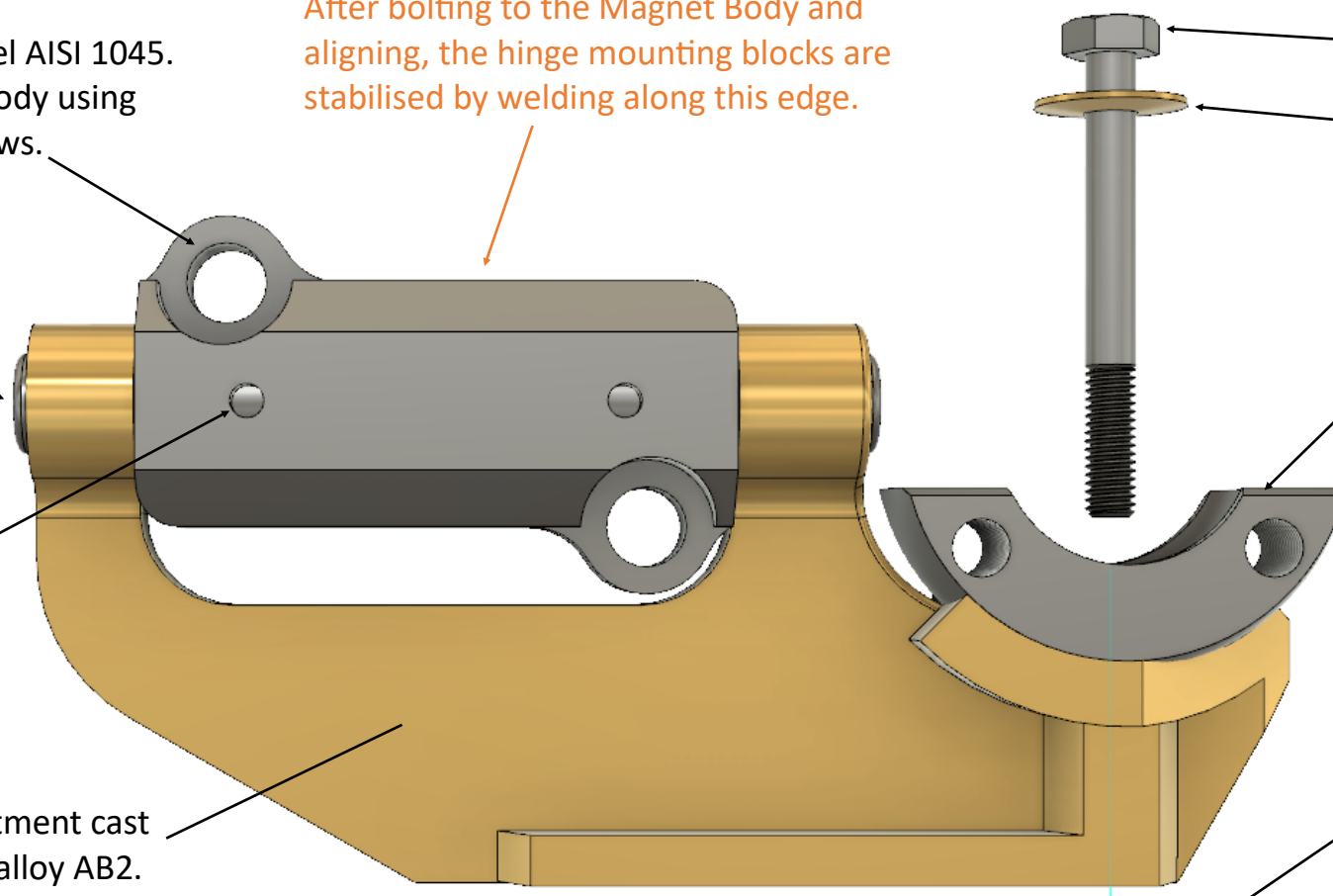

M6 x 55 HEX HD SCREW

BRASS WASHER.
M6 x 12 x 1.0. Dished to
R17 using special tool.

SECTOR BLOCK. Investment
cast steel AISI 1045.
Mount to Bending Beam with
2 M8 x 20 CS socket screws,

2 x Belleville spring washers,
6.2 x 0.7 (JW414).
Assemble cup-to-cup.

2 x M6 locknuts.
Loctite with #290.